

FasGrid - Pultruded Fiberglass Grating

Pultrusion technology is a manufacturing process which produces uniform cross-sectionally shaped glass-fiber reinforced polymer composite profiles. These profiles are designed to compete with the strength properties of traditional metal grating structures, but offer the inherent environmental benefits that come with using fiberglass. The fiberglass reinforced polymer matrix is ideal for corrosive environments and greatly reduces the maintenance required over the life-time of the grating.

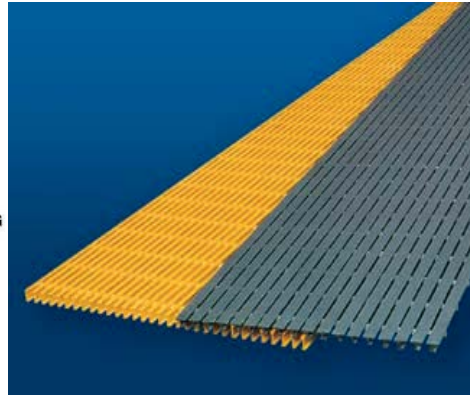
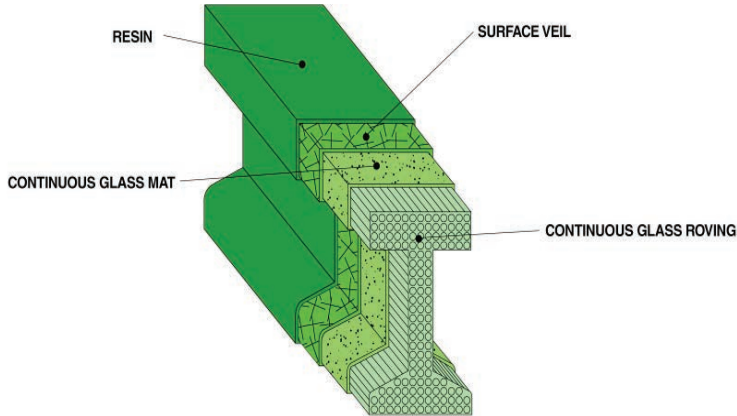

Key Features

- Corrosion Resistant
- High Strength
- Fatigue Resistant
- Lightweight
- Easy to Fabricate & Install
- Fire Retardant
- Maintenance free
- Non-conductive
- Low Thermal Conductivity
- Slip Resistant
- Rust Free & Weather Proof
- Cost Effective
- Uniform in appearance
- UV Resistant

Applications

Pultruded fiberglass grating is designed and used in a wide variety of applications, such as:

- Chemical Plants
- Marine/Offshore
- Petrochemical Plants
- Shipping Docks
- Pulp & Paper Mills
- Water Treatment Plants
- Processing Plants
- Oil Rigs
- Food Processing
- Transportation Industry
- Communication Industry
- General Industry
- Mining Industry
- Power Plants

Product Selection

Part Number	Bar Type	Thickness (in)	Size (ft)	Color	Resin Type	Open Area (%)	Bars (per ft)	Aprox. Wt. (lb/ft ²)
IG6010-PP-Y-320	I	1.0	3 x 20	Yellow	Preium Polyester	60	8	2.39
IG6010-PP-DGY-320	I	1.0	3 x 20	Grey	Preium Polyester	60	8	2.39
IG6010-PP-Y-420	I	1.0	4 x 20	Yellow	Preium Polyester	60	8	2.39
IG6010-PP-DGY-420	I	1.0	4 x 20	Grey	Preium Polyester	60	8	2.39
IG6015-PP-Y-320	I	1.5	3 x 20	Yellow	Preium Polyester	60	8	2.95
IG6015-PP-DGY-320	I	1.5	3 x 20	Grey	Preium Polyester	60	8	2.95
IG6015-PP-Y-420	I	1.5	4 x 20	Yellow	Preium Polyester	60	8	2.95
IG6015-PP-DGY-420	I	1.5	4 x 20	Grey	Preium Polyester	60	8	2.95
TG5020-PP-DGY-320	T	2.0	3 x 20	Grey	Preium Polyester	50	6	3.38
TG5020-PP-DGY-420	T	2.0	4 x 20	Grey	Preium Polyester	50	6	3.38

Panel Dimensions

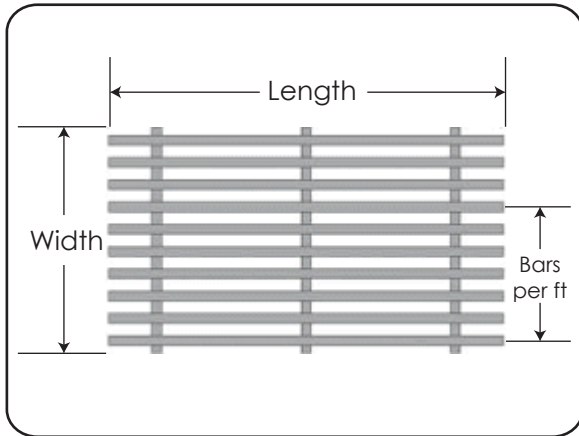

Cross-rod System

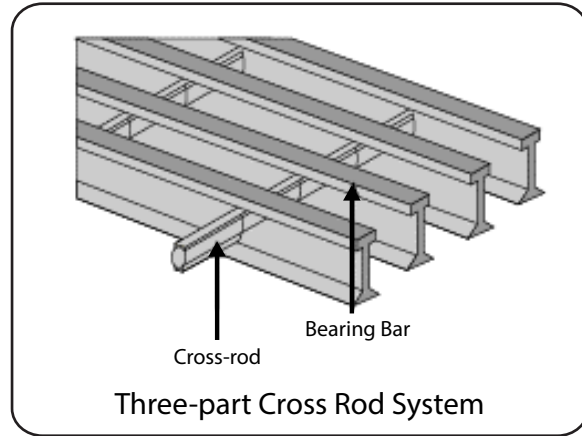

Mechanical Properties of Pultruded Grating

Property	Test Method	I-Series (70-75% Glass)	T-Series (60-65% Glass)
Tensile Strength	ASTM D638	125,000 psi	100,000 psi
Tensile Modulus	ASTM D638	6 x 10 ⁴ psi	5.6 x 10 ⁴ psi
Flexural Strength	ASTM D790	125,000 psi	100,000 psi
Flexural Modulus	ASTM D790	6 x 10 ⁴ psi	5.6 x 10 ⁴ psi
Compressive Strength	ASTM D695	65,000 psi	60,000 psi
Izod Impact Notch	ASTM D256	40 ft-lb/in	40 ft-lb/in
Barcol Hardness	ASTM D2583	50 (min)	50 (min)
Specific Gravity	ASTM D792	2	2
Water Absorption	ASTM D570	Max 0.3%	Max 0.3%

Resin Selection

Selecting the correct resin type is critical in providing corrosion resistance and ensuring the life-time dependability and performance of the grating. If you are unsure which resin type fits your application's needs, feel free to contact us.

Type PP is a premium isophthalic polyester resin. It is a popular choice for most applications due to its good corrosion resistance properties and relative low cost. This type of resin is most commonly used in applications where there is a possibility of a splash or spill of harsh chemicals.

Load Table - IG - 1" Thick

SPAN INCHES		LOAD IN LBS - DEFLECTION IN INCHES								SAFE LOAD LBS
		50	100	150	200	250	500	1000	2000	
		12	ΔU	<0.01	<0.01	<0.01	<0.01	<0.01	0.01	
	ΔC	<0.01	<0.01	<0.01	0.01	0.01	0.02	0.04	0.08	5044
18	ΔU	<0.01	<0.01	0.01	0.02	0.02	0.05	0.09	0.19	4805
	ΔC	<0.01	0.01	0.02	0.02	0.03	0.05	0.10		3605
24	ΔU	0.01	0.03	0.04	0.05	0.07	0.13			2813
	ΔC	0.01	0.02	0.03	0.04	0.05	0.10	0.21		2813
30	ΔU	0.03	0.06	0.09	0.12	0.15				1800
	ΔC	0.02	0.04	0.06	0.08	0.10	0.19	0.39		2250
36	ΔU	0.06	0.12	0.18	0.24	0.31				1250
	ΔC	0.03	0.07	0.10	0.13	0.16	0.33			1875
42	ΔU	0.11	0.22	0.33	0.44					915
	ΔC	0.05	0.10	0.15	0.20	0.25				1600
48	ΔU	0.19	0.37							697
	ΔC	0.07	0.15	0.22	0.30	0.37				1394
54	ΔU	0.30								549
	ΔC	0.11	0.21	0.32	0.42					1236

Specifications

60% Open Area

A = 2.496 in²/ft of width

S = 0.656 in³/ft of width

I = 0.326 in⁴/ft of width

Approx. Wt. = 2.39 lbs/sq.ft

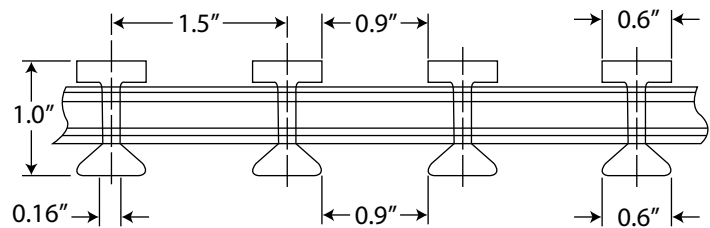

Uniform Load

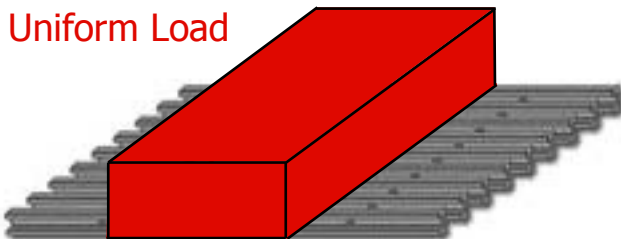

U = Uniform load - lbs/ft of width
 ΔU = Uniform load deflection (in/mm)

Concentrated Line Load

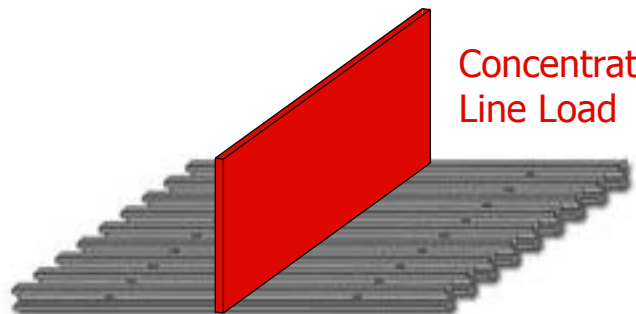

C = Concentrated line load - lbs/ft
 ΔC = Concentrated line load deflection (in/mm)

Load Table - IG -1.5" Thick

SPAN INCHES		LOAD IN LBS - DEFLECTION IN INCHES								SAFE LOAD
		50	100	150	200	250	500	1000	2000	
		LBS								
12	ΔU	<0.01	<0.01	<0.01	<0.01	<0.01	0.01	0.01	0.02	17073
	ΔC	<0.01	<0.01	<0.01	<0.01	<0.01	0.01	0.02	0.04	8536
18	ΔU	<0.01	<0.01	0.01	0.01	0.01	0.02	0.04	0.08	7588
	ΔC	<0.01	<0.01	0.01	0.01	0.01	0.02	0.04	0.08	5691
24	ΔU	0.01	0.01	0.02	0.02	0.03	0.05	0.10	0.21	4268
	ΔC	<0.01	0.01	0.01	0.02	0.02	0.04	0.08	0.17	4268
30	ΔU	0.01	0.02	0.03	0.05	0.06	0.12	0.23		2690
	ΔC	0.01	0.01	0.02	0.03	0.04	0.07	0.15	0.30	3363
36	ΔU	0.02	0.05	0.07	0.09	0.11	0.23			1839
	ΔC	0.01	0.02	0.04	0.05	0.06	0.12	0.24		2760
42	ΔU	0.04	0.08	0.12	0.17	0.21	0.41			1320
	ΔC	0.02	0.04	0.06	0.08	0.09	0.19	0.38		2310
48	ΔU	0.07	0.14	0.21	0.28	0.35				986
	ΔC	0.03	0.06	0.08	0.11	0.14	0.28			1972
54	ΔU	0.11	0.22	0.34	0.45					754
	ΔC	0.04	0.08	0.12	0.16	0.20	0.40			1696
60	ΔU	0.17	0.34							590
	ΔC	0.05	0.11	0.16	0.22					1474
66	ΔU	0.25	0.50							470
	ΔC	0.07	0.15	0.22	0.29					1293

Specifications

60% Open Area

A = 3.136 in²/ft of width

S = 1.239 in³/ft of width

I = 0.928 in⁴/ft of width

Approx. Wt. = 2.95 lbs/sq.ft

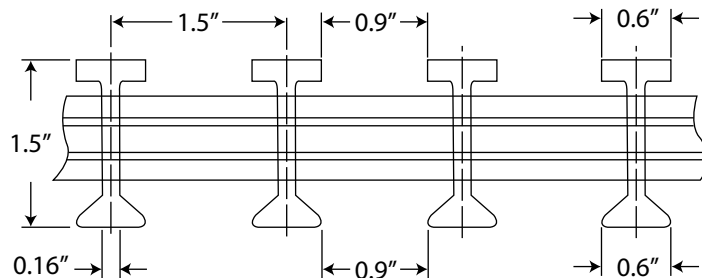

Load Table Notes

- The designer should not exceed the recommended safe load at any time. The safe load represents a 2:1 factor of safety.
- Walking loads, typically 50 PSF is recommended for pedestrian traffic. Deflections for worker comfort are typically limited to 3/8in or SPAN divided by 120 under full loads. For a more rigid feel under full loads, limit deflection to 1/4in or SPAN divided by 200.
- The allowable loads are for static conditions at ambient temperatures. Allowable loads for impact or dynamic loads should be a maximum of 1/2 the value shown. Long term loads will likely result in added deflection due to creep in the material and will also require higher safety factors to ensure acceptable performance.

Load Table - TG - 2" Thick

SPAN INCHES		LOAD IN LBS - DEFLECTION IN INCHES								SAFE LOAD
		50	100	150	200	250	500	1000	2000	LBS
12	ΔU	<0.01	<0.01	<0.01	<0.01	<0.01	<0.01	0.01	0.01	10993
	ΔC	<0.01	<0.01	<0.01	<0.01	<0.01	0.01	0.02	0.02	5496
18	ΔU	<0.01	<0.01	0.00	0.01	0.01	0.01	0.03	0.03	7310
	ΔC	<0.01	<0.01	<0.01	0.01	0.01	0.01	0.03	0.04	5496
24	ΔU	<0.01	0.01	0.01	0.01	0.02	0.03	0.07	0.11	5496
	ΔC	<0.01	<0.01	0.01	0.01	0.01	0.03	0.05	0.08	5496
30	ΔU	0.01	0.01	0.02	0.03	0.04	0.07	0.14	0.25	3517
	ΔC	<0.01	0.01	0.01	0.02	0.02	0.05	0.09	0.16	4398
36	ΔU	0.01	0.03	0.04	0.06	0.07	0.14	0.28	0.52	2443
	ΔC	0.01	0.01	0.02	0.03	0.04	0.07	0.15	0.27	3665
42	ΔU	0.02	0.05	0.07	0.10	0.12	0.25			1795
	ΔC	0.01	0.02	0.03	0.05	0.06	0.11	0.23	0.44	3141
48	ΔU	0.04	0.08	0.12	0.17	0.21	0.41			1374
	ΔC	0.02	0.03	0.05	0.07	0.08	0.17	0.33	0.63	2749
54	ΔU	0.06	0.13	0.19	0.26	0.32				1086
	ΔC	0.02	0.05	0.07	0.09	0.11	0.23	0.46		2443
60	ΔU	0.10	0.2	0.29	0.39	0.49				880
	ΔC	0.03	0.06	0.09	0.13	0.16	0.31			2199
66	ΔU	0.14	0.29	0.43						727
	ΔC	0.04	0.08	0.12	0.17	0.21	0.42			1998
72	ΔU	0.20	0.40							610
	ΔC	0.05	0.11	0.16	0.22	0.27				1832
78	ΔU	0.28								520
	ΔC	0.07	0.14	0.20	0.27	0.34				1692
84	ΔU	0.37								449
	ΔC	0.09	0.17	0.26	0.34	0.43				1570

Specifications

50% Open Area

A = 3.253 in²/ft of width

ST = 1.906 in³/ft of width

SE = 1.496 in³/ft of width

I = 1.676 in⁴/ft of width

Approx. Wt. = 3.38 lbs/sq.ft

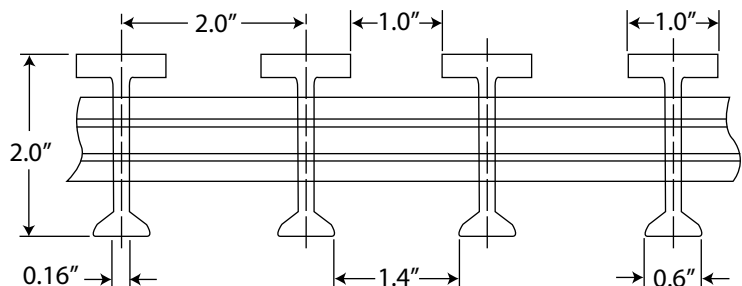

Chemical Resistance Chart for Pultruded Grating

Chemical	Resin Type: Premium Polyester		Chemical	Resin Type: Premium Polyester	
	Concentration %	Max Operating Temperature °C/°F		Concentration %	Max Operating Temperature °C/°F
Acetic Acid	50	125/52	Lithium Chloride	SAT	150/66
Aluminum Hydroxide	100	160/71	Magnesium Chloride	ALL	170/77
Ammonium Chloride	ALL	170/77	Magnesium Nitrate	ALL	140/60
Ammonium Hydroxide	28	N/R	Magnesium Sulfate	ALL	170/77
Ammonium Bicarbonate	15	125/52	Mercuric Chloride	100	150/66
Ammonium Sulfate	ALL	170/77	Mercurous Chloride	ALL	140/60
Benzene	N/R	N/R	Nickel Chloride	ALL	170/77
Benzoic Acid	SAT	150/66	Nickel Sulfate	ALL	170/77
Borax	SAT	170/77	Nitric Acid	20	70/21
Calcium Carbonate	ALL	170/77	Oxalic Acid	ALL	75/24
Calcium Nitrate	ALL	180/82	Perchloric Acid	N/R	N/R
Carbon Tetrachloride	N/R	N/R	Phosphoric Acid	100	120/49
Chlorine (Dry Gas)	-	140/60	Potassium Chloride	ALL	170/77
Chlorine (Water)	SAT	80/27	Potassium Dichromate	ALL	170/77
Chromic Acid	5	70/21	Potassium Nitrate	ALL	170/77
Citric Acid	ALL	170/77	Potassium Sulfate	ALL	170/77
Copper Chloride	ALL	170/77	Propylene Glycol	ALL	170/77
Copper Cyanide	ALL	170/77	Sodium Acetate	ALL	160/71
Copper Nitrate	ALL	170/77	Sodium Bisulfate	ALL	170/77
Ethanol	50	75/24	Sodium Bromide	ALL	170/77
Ethylene Glycol	100	90/32	Sodium Cyanide	ALL	170/77
Ferric Chloride	ALL	170/77	Sodium Hydroxide	N/R	N/R
Ferrous Chloride	ALL	170/77	Sodium Nitrate	ALL	170/77
Formaldehyde	50	75/24	Sodium Sulfate	ALL	170/77
Gasoline	100	80/27	Stannic Chloride	ALL	160/71
Glucose	100	170/77	Sulfuric Acid	25	75/24
Glycerine	100	150/66	Tartaric Acid	ALL	170/77
Hydrobromic Acid	50	120/49	Vinegar	100	170/77
Hydrochloric Acid	37	75/24	Water (Distilled)	100	170/77
Hydrogen Peroxide	5	100/38	Zinc Nitrate	ALL	170/77
Lactic Acid	ALL	170/77	Zinc Sulfate	ALL	170/77

ALL - All Concentrations SAT - Saturated Solution N/R - Not Recommended '-' No Information Available

■ Notes

The chemical resistance chart is to be used as a general reference guide. Resin manufacturers have provided data which indicates that specific resins can withstand the corrosion conditions listed. Testing for specific environments is recommended if the environment is unknown. North American Grating believes the following data to be true and accurate but does not guarantee expressed or implied performance from the data presented.

Clips & Accessories

Saddle Clips

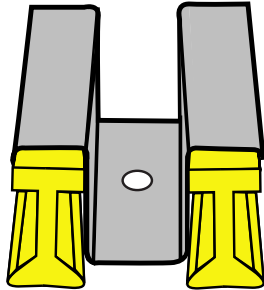

Model: SSC & STC

Sizes

1"	SSC10
1-1/2"	SSC15
2"	STC20

- 316 Stainless Steel
- Typically used for attaching grating to structural supports and joining two panels together
- Available in 3 sizes
- Model SSC is used for I-Bar grating
- Model STC is used for T-Bar grating

Curb Angle

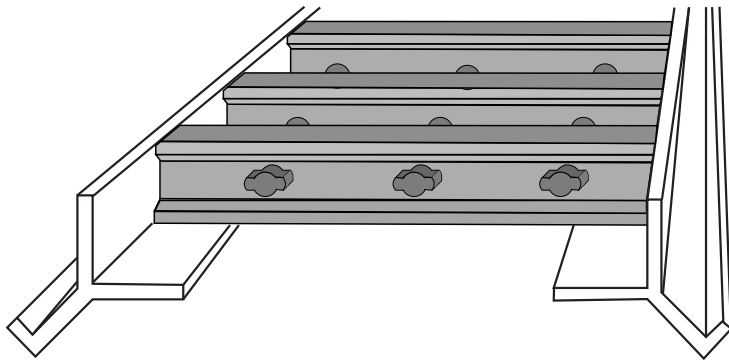

- Pultruded Fiberglass curb angle
- Provides a strong and sturdy base for pultruded grating
- Typically used in drainage, irrigation and structural applications
- Available in 3 sizes

